

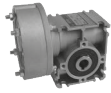

Baugröße / Size

Seite / Page



a = 31	Eintriebshohlwelle Zubehör	Hollow input shaft Accessories	B-3 B-5
a = 40	Eintriebshohlwelle Zubehör	Hollow input shaft Accessories	B-6 B-9
a = 50	Eintriebshohlwelle Zubehör	Hollow input shaft Accessories	B-10 B-13
a = 63	Eintriebshohlwelle Zubehör	Hollow input shaft Accessories	B-14 B-17



Auswahltabellen und Beispiel	Selection tables and example	B-18
------------------------------	------------------------------	------



Zulässige Zusatzkräfte	Permissible additional loads	B-19
------------------------	------------------------------	------



Kurzbeschreibung	Short description	B-19
------------------	-------------------	------





**Achsabstand / Centre distance**  $a_o = 31$  mm für B5 Motor / for B5 motor

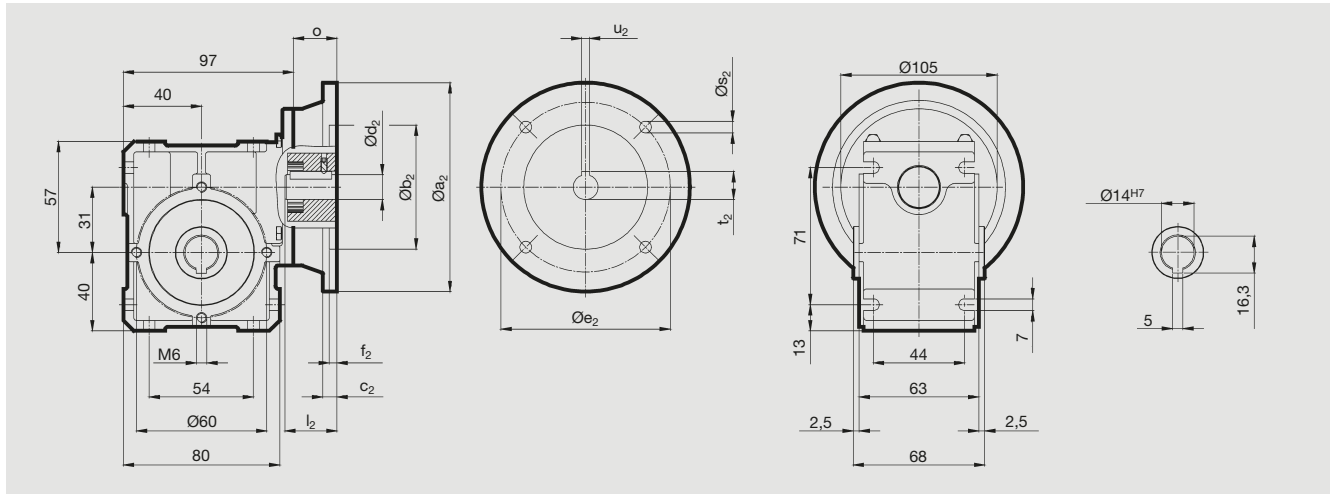

Bestell-Nr. Order code	Übersetzung Ratio	Antriebsflansch Driving flange	a <sub>2</sub>	b <sub>2</sub>	c <sub>2</sub>	d <sub>2</sub>	e <sub>2</sub>	f <sub>2</sub>	l <sub>2</sub>	o	s <sub>2</sub>	t <sub>2</sub>	u <sub>2</sub>	kg
76 31 305	5													
76 31 310	10													
76 31 320	20	IEC 56 B5 A120	120	80	8	9	100	3,5	20	29,5	7	11,4	3	1,5
76 31 330	30													
76 31 340	40													
76 31 350	50													
76 31 405	5													
76 31 410	10													
76 31 420	20	IEC 63 B5 A140	140	95	8	11	115	3,5	23	29,5	9	12,8	4	1,5
76 31 430	30													
76 31 440	40													
76 31 450	50													

**Andere Übersetzungen auf Anfrage / Other ratios on request**



**ATLANTA**

**Grundgetriebe mit Antriebs-Hohlwelle**  
Basic gear with input hollow shaft

**Achsabstand / Centre distance**  $a_o = 31$  mm für B14 Motor / for B14 motor

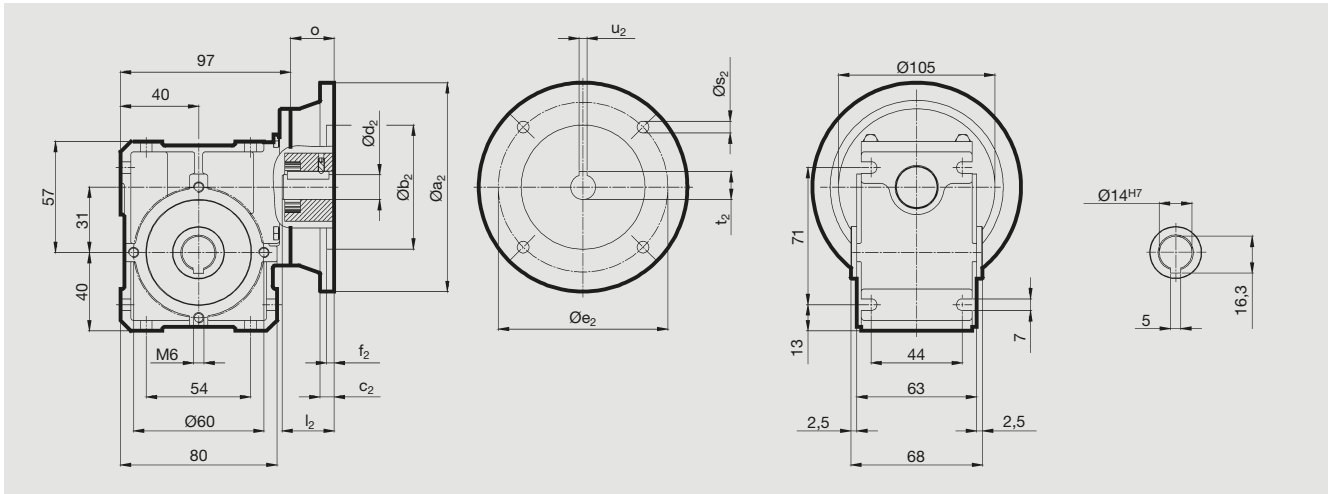

Bestell-Nr. Order code	Übersetzung Ratio	Antriebsflansch Driving flange	$a_2$	$b_2$	$c_2$	$d_2$	$e_2$	$f_2$	$l_2$	$o$	$s_2$	$t_2$	$u_2$	kg
76 41 205	5													
76 41 210	10													
76 41 220	20	IEC 56 B14 C105	105	70	8	9	85	3	20	29,5	7	11,4	3	1,5
76 41 230	30													
76 41 240	40													
76 41 250	50													
76 41 105	5													
76 41 110	10													
76 41 120	20	IEC 63 B14 C90	90	60	8	11	75	3	23	29,5	6	12,8	4	1,5
76 41 130	30													
76 41 140	40													
76 41 150	50													
76 41 305	5													
76 41 310	10													
76 41 320	20	IEC 63 B14 C120	120	80	8	11	100	3,5	23	29,5	7	12,8	4	1,5
76 41 330	30													
76 41 340	40													
76 41 350	50													
76 41 605	5													
76 41 610	10													
76 41 620	20	IEC 71 B14 C105	105	70	8	14	85	3	30	29,5	7	16,3	5	1,5
76 41 630	30													
76 41 640	40													
76 41 650	50													
76 41 405	5													
76 41 410	10													
76 41 420	20	IEC 71 B14 C140	140	95	8	14	115	3,5	30	29,5	9	16,3	5	1,5
76 41 430	30													
76 41 440	40													
76 41 450	50													

**Andere Übersetzungen auf Anfrage / Other ratios on request**



Achsabstand / Centre distance  $a_o = 31 \text{ mm}$

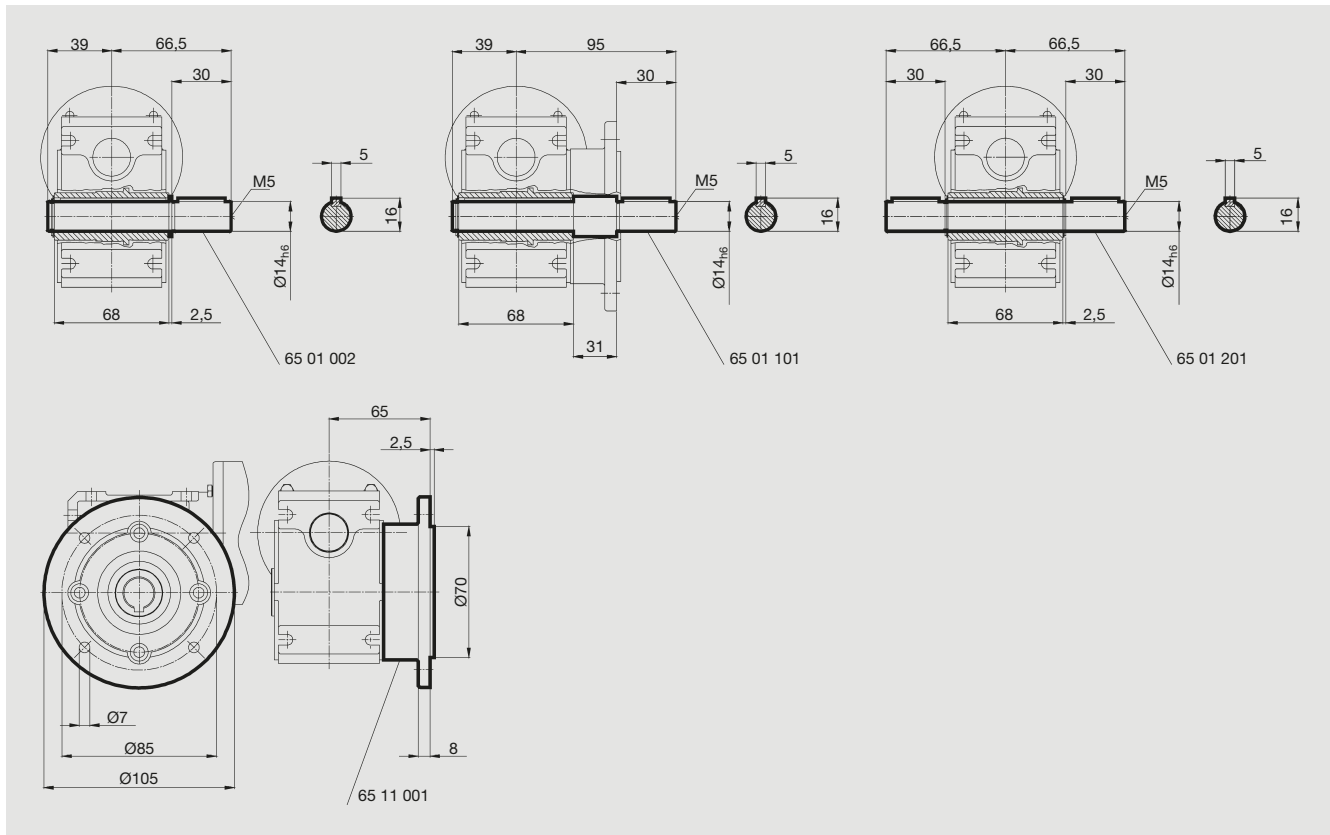

Bestell-Nr. Order code	Bild Fig.	Bezeichnung Description		kg
65 01 002	1	<b>Abtriebswelle einseitig kurz</b>	output shaft, one side, short	0,15
65 01 101	2	<b>Abtriebswelle einseitig lang</b>	output shaft, one side, long	0,25
65 01 201	3	<b>Abtriebswelle beidseitig</b>	output shaft, both sides	0,20
65 11 001	4	<b>Abtriebsflansch</b>	output flange	0,20



**ATLANTA**

**Grundgetriebe mit Antriebs-Hohlwelle**  
Basic gear with input hollow shaft

**Achsabstand / Centre distance**  $a_o = 40 \text{ mm}$  für B5 Motor / for B5 motor

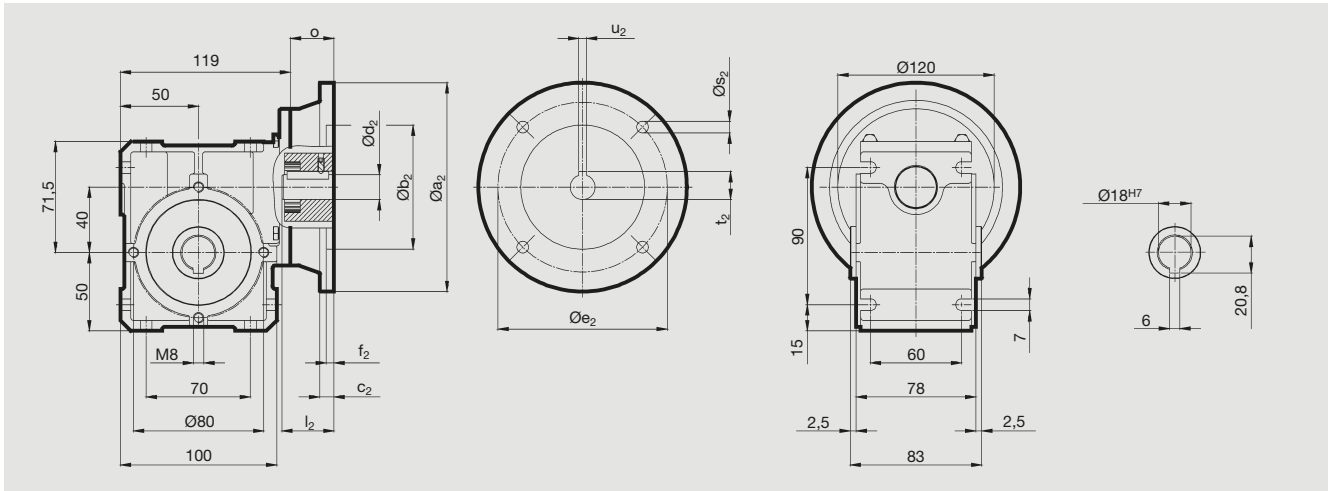

Bestell-Nr. Order code	Übersetzung Ratio	Antriebsflansch Driving flange	$a_2$	$b_2$	$c_2$	$d_2$	$e_2$	$f_2$	$l_2$	$o$	$s_2$	$t_2$	$u_2$	kg
76 32 305	5													
76 32 310	10													
76 32 320	20	IEC 56 B5 A120	120	80	8	9	100	3,5	20	32,5	7	11,4	3	2,6
76 32 330	30													
76 32 340	40													
76 32 350	50													
76 32 405	5													
76 32 410	10													
76 32 420	20	IEC 63 B5 A140	140	95	8	11	115	3,5	23	32,5	9	12,8	4	2,6
76 32 430	30													
76 32 440	40													
76 32 450	50													
76 32 505	5													
76 32 510	10													
76 32 520	20	IEC 71 B5 A160	160	110	8	14	130	4	30	32,5	9	16,3	5	2,6
76 32 530	30													
76 32 540	40													
76 32 550	50													
76 32 605	5													
76 32 610	10													
76 32 620	20	IEC 80 B5 A200	200	130	10	19	165	4	40	32,5	M10	21,8	6	2,6
76 32 630	30													
76 32 640	40													
76 32 650	50													

**Andere Übersetzungen auf Anfrage / Other ratios on request**



**Achsabstand / Centre distance**  $a_o = 40$  mm für B14 Motor / for B14 motor

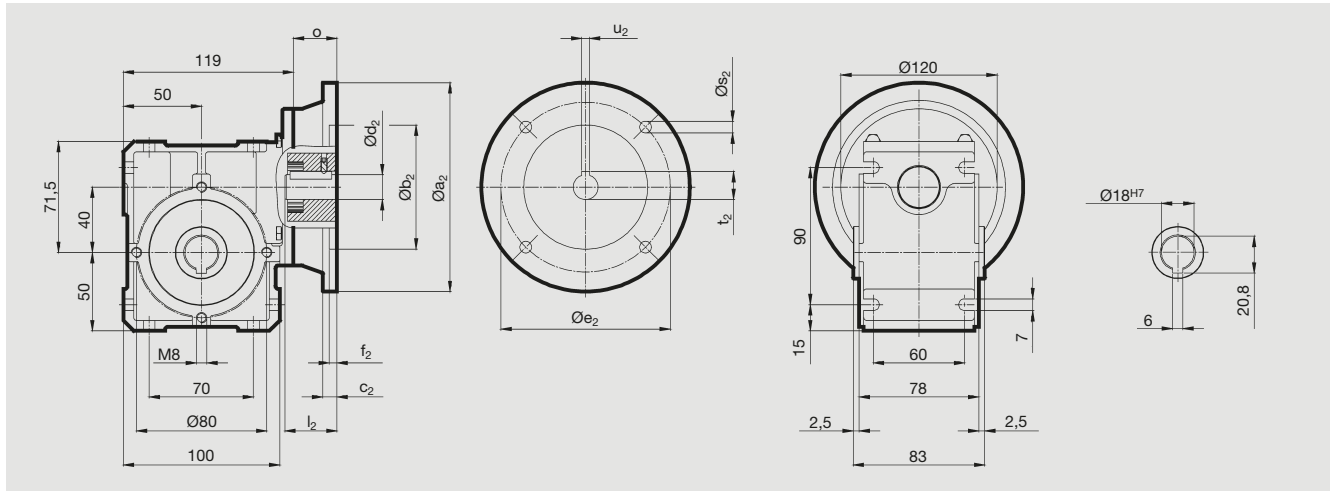

Bestell-Nr. Order code	Übersetzung Ratio	Antriebsflansch Driving flange	$a_2$	$b_2$	$c_2$	$d_2$	$e_2$	$f_2$	$l_2$	$o$	$s_2$	$t_2$	$u_2$	kg
76 42 205	5													
76 42 210	10													
76 42 220	20	IEC 56 B14 C105	105	70	8	9	85	3	20	32,5	7	11,4	3	2,6
76 42 230	30													
76 42 240	40													
76 42 250	50													
76 42 105	5													
76 42 110	10													
76 42 120	20	IEC 63 B14 C90	90	60	8	11	75	3	23	32,5	6	12,8	4	2,6
76 42 130	30													
76 42 140	40													
76 42 150	50													
76 42 305	5													
76 42 310	10													
76 42 320	20	IEC 63 B14 C120	120	80	8	11	100	3,5	23	32,5	7	12,8	4	2,6
76 42 330	30													
76 42 340	40													
76 42 350	50													
76 42 605	5													
76 42 610	10													
76 42 620	20	IEC 71 B14 C105	105	70	8	14	85	3	30	32,5	7	16,3	5	2,6
76 42 630	30													
76 42 640	40													
76 42 650	50													

Andere Übersetzungen auf Anfrage / Other ratios on request



**ATLANTA**

**Grundgetriebe mit Antriebs-Hohlwelle**  
Basic gear with input hollow shaft

**Achsabstand / Centre distance**  $a_o = 40$  mm für B14 Motor / for B14 motor

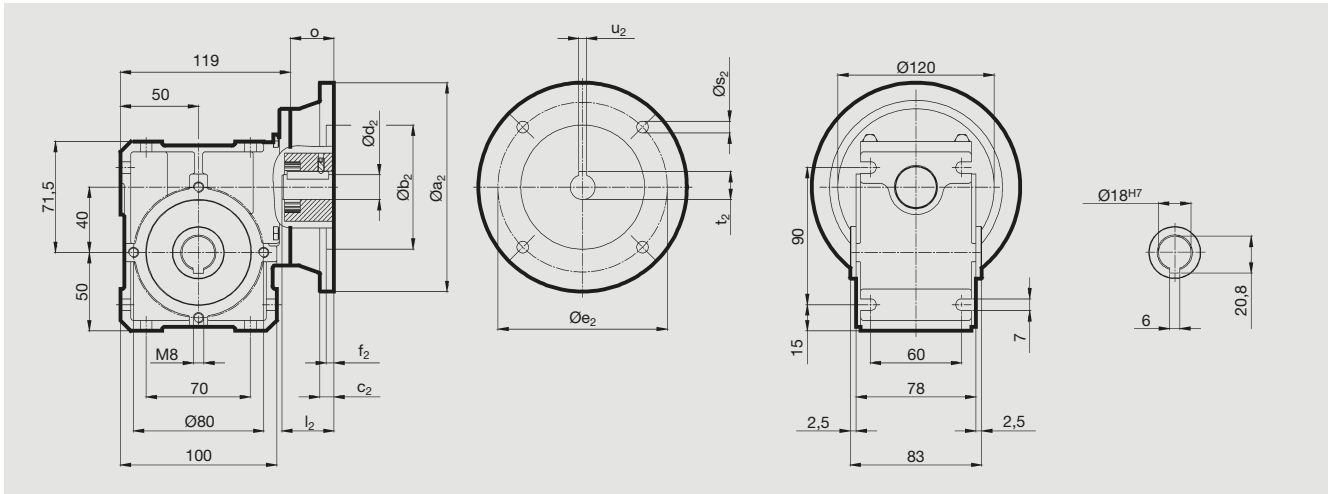

Bestell-Nr. Order code	Übersetzung Ratio	Antriebsflansch Driving flange	$a_2$	$b_2$	$c_2$	$d_2$	$e_2$	$f_2$	$l_2$	$o$	$s_2$	$t_2$	$u_2$	kg
76 42 405	5													
76 42 410	10													
76 42 420	20	IEC 71 B14 C140	140	95	8	14	115	3,5	30	32,5	9	16,3	5	2,6
76 42 430	30													
76 42 440	40													
76 42 450	50													
76 42 705	5													
76 42 710	10													
76 42 720	20	IEC 80 B14 C120	120	80	8	19	100	3,5	40	32,5	7	21,8	6	2,6
76 42 730	30													
76 42 740	40													
76 42 750	50													
76 42 505	5													
76 42 510	10													
76 42 520	20	IEC 80 B14 C160	160	110	8	19	130	4	40	32,5	9	21,8	6	2,6
76 42 530	30													
76 42 540	40													
76 42 550	50													

**Andere Übersetzungen auf Anfrage / Other ratios on request**

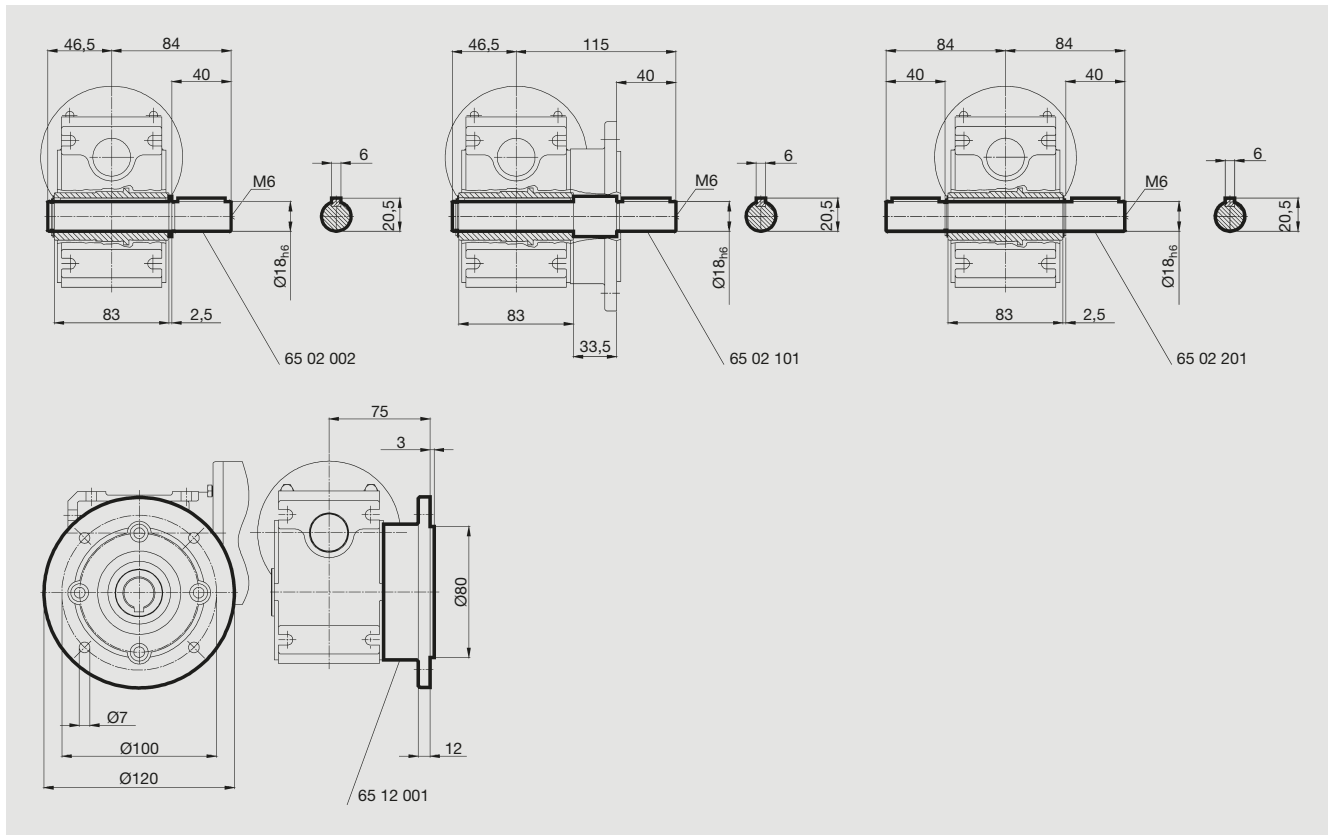

**Achsabstand / Centre distance**  $a_o = 40 \text{ mm}$ 

Bestell-Nr. Order code	Bild Fig.	Bezeichnung Description		kg
65 02 002	1	<b>Abtriebswelle einseitig kurz</b>	output shaft, one side, short	0,30
65 02 101	2	<b>Abtriebswelle einseitig lang</b>	output shaft, one side, long	0,45
65 02 201	3	<b>Abtriebswelle beidseitig</b>	output shaft, both sides	0,35
65 12 001	4	<b>Abtriebsflansch</b>	output flange	0,22



# ATLANTA

## Grundgetriebe mit Antriebs-Hohlwelle Basic gear with input hollow shaft

**Achsabstand / Centre distance**  $a_o = 50 \text{ mm}$  für B5 Motor / for B5 motor

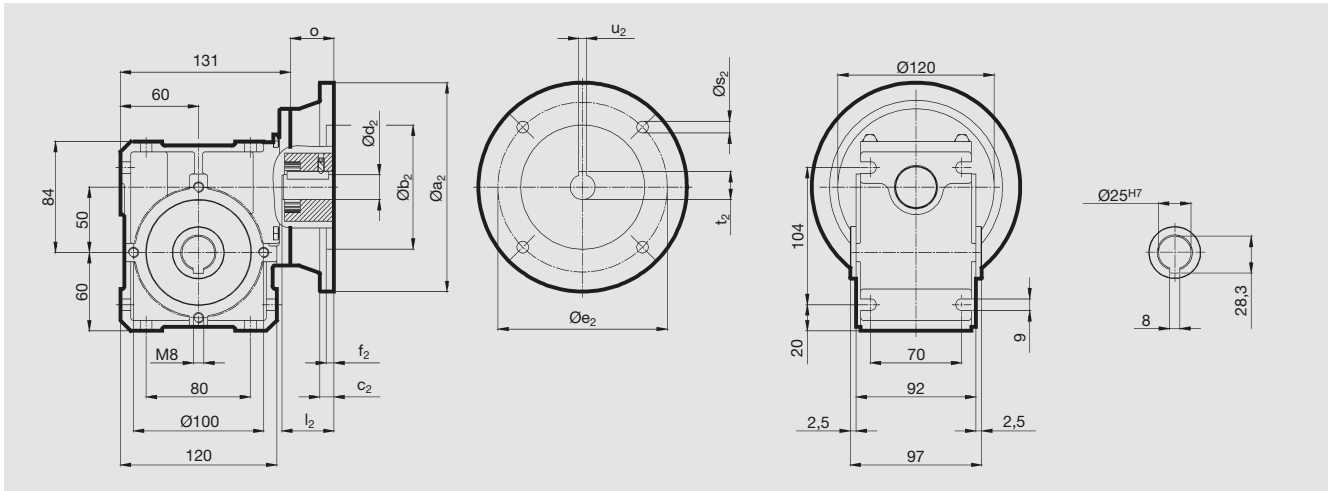

Bestell-Nr. Order code	Übersetzung Ratio	Antriebsflansch Driving flange	$a_2$	$b_2$	$c_2$	$d_2$	$e_2$	$f_2$	$l_2$	$o$	$s_2$	$t_2$	$u_2$	kg
76 33 305	5													
76 33 310	10													
76 33 320	20	IEC 56 B5 A120	120	80	8	9	100	3,5	20	32,5	7	11,4	3	4,3
76 33 330	30													
76 33 340	40													
76 33 350	50													
76 33 405	5													
76 33 410	10													
76 33 420	20	IEC 63 B5 A140	140	95	8	11	115	3,5	23	32,5	9	12,8	4	4,3
76 33 430	30													
76 33 440	40													
76 33 450	50													
76 33 505	5													
76 33 510	10													
76 33 520	20	IEC 71 B5 A160	160	110	8	14	130	4	30	32,5	9	16,3	5	4,3
76 33 530	30													
76 33 540	40													
76 33 550	50													
76 33 605	5													
76 33 610	10													
76 33 620	20	IEC 80 B5 A200	200	130	10	19	165	4	40	32,5	M10	21,8	6	4,3
76 33 630	30													
76 33 640	40													
76 33 650	50													

Andere Übersetzungen auf Anfrage / Other ratios on request



**Achsabstand / Centre distance**  $a_o = 50$  mm für B14 Motor / for B14 motor

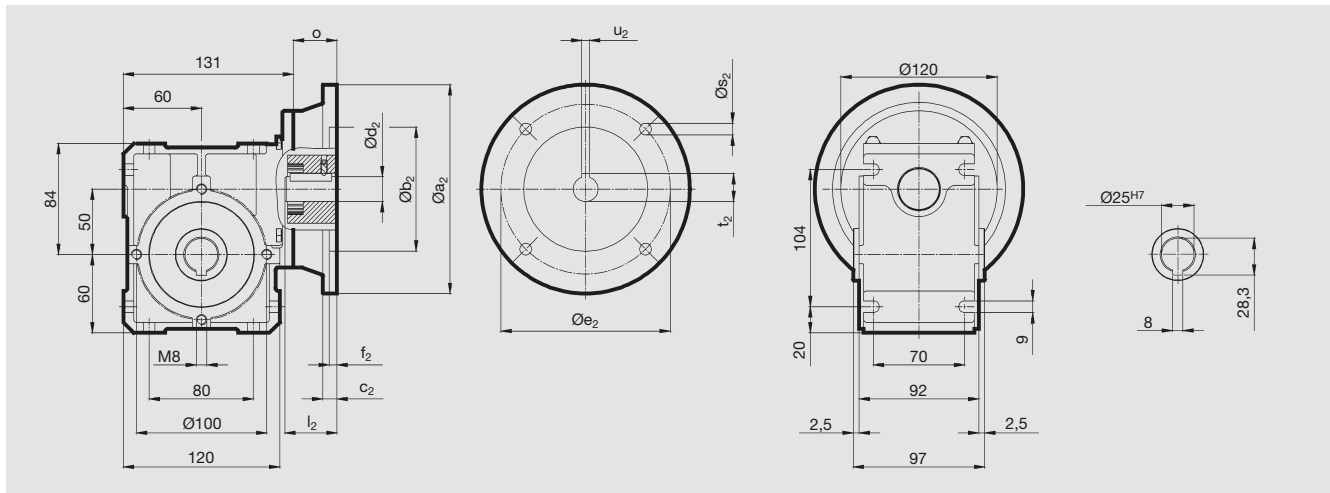

Bestell-Nr. Order code	Übersetzung Ratio	Antriebsflansch Driving flange	$a_2$	$b_2$	$c_2$	$d_2$	$e_2$	$f_2$	$l_2$	$o$	$s_2$	$t_2$	$u_2$	kg
76 43 205	5													
76 43 210	10													
76 43 220	20	IEC 56 B14 C105	105	70	8	9	85	3	20	32,5	7	11,4	3	4,3
76 43 230	30													
76 43 240	40													
76 43 250	50													
76 43 105	5													
76 43 110	10													
76 43 120	20	IEC 63 B14 C90	90	60	8	11	75	3	23	32,5	6	12,8	4	4,3
76 43 130	30													
76 43 140	40													
76 43 150	50													
76 43 305	5													
76 43 310	10													
76 43 320	20	IEC 63 B14 C120	120	80	8	11	100	3,5	23	32,5	7	12,8	4	4,3
76 43 330	30													
76 43 340	40													
76 43 350	50													
76 43 605	5													
76 43 610	10													
76 43 620	20	IEC 71 B14 C105	105	70	8	14	85	3	30	32,5	7	16,3	5	4,3
76 43 630	30													
76 43 640	40													
76 43 650	50													

Andere Übersetzungen auf Anfrage / Other ratios on request



**ATLANTA**

**Grundgetriebe mit Antriebs-Hohlwelle**  
Basic gear with input hollow shaft

**Achsabstand / Centre distance**  $a_o = 50 \text{ mm}$  für B14 Motor / for B14 motor

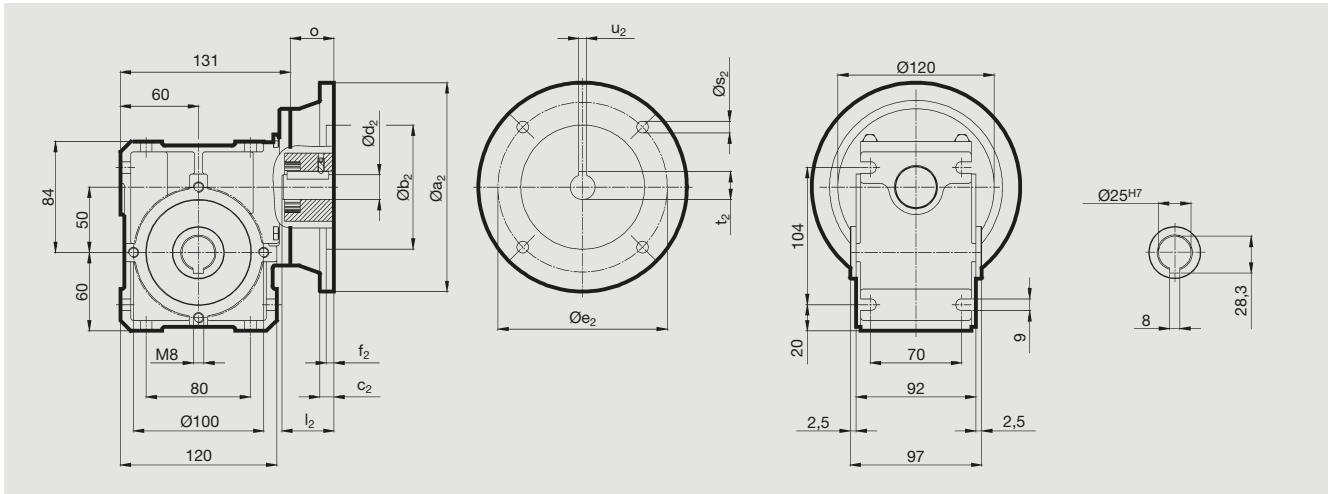

Bestell-Nr. Order code	Übersetzung Ratio	Antriebsflansch Driving flange	$a_2$	$b_2$	$c_2$	$d_2$	$e_2$	$f_2$	$l_2$	$o$	$s_2$	$t_2$	$u_2$	kg
76 43 405	5													
76 43 410	10													
76 43 420	20	IEC 71 B14 C140	140	95	8	14	115	3,5	30	32,5	9	16,3	5	4,3
76 43 430	30													
76 43 440	40													
76 43 450	50													
76 43 705	5													
76 43 710	10													
76 43 720	20	IEC 80 B14 C120	120	80	8	19	100	3,5	40	32,5	7	21,8	6	4,3
76 43 730	30													
76 43 740	40													
76 43 750	50													
76 43 505	5													
76 43 510	10													
76 43 520	20	IEC 80 B14 C160	160	110	8	19	130	4	40	32,5	9	21,8	6	4,3
76 43 530	30													
76 43 540	40													
76 43 550	50													
76 43 805	5													
76 43 810	10													
76 43 820	20	IEC 90 B14 C140	140	95	8	24	115	3,5	50	45,5	9	27,3	8	4,3
76 43 830	30													
76 43 840	40													
76 43 850	50													
76 43 905	5													
76 43 910	10													
76 43 920	20	IEC 90 B14 C160	160	110	8	24	130	4	50	45,5	9	27,3	8	4,3
76 43 930	30													
76 43 940	40													
76 43 950	50													

**Andere Übersetzungen auf Anfrage / Other ratios on request**



Achsabstand / Centre distance  $a_o = 50 \text{ mm}$

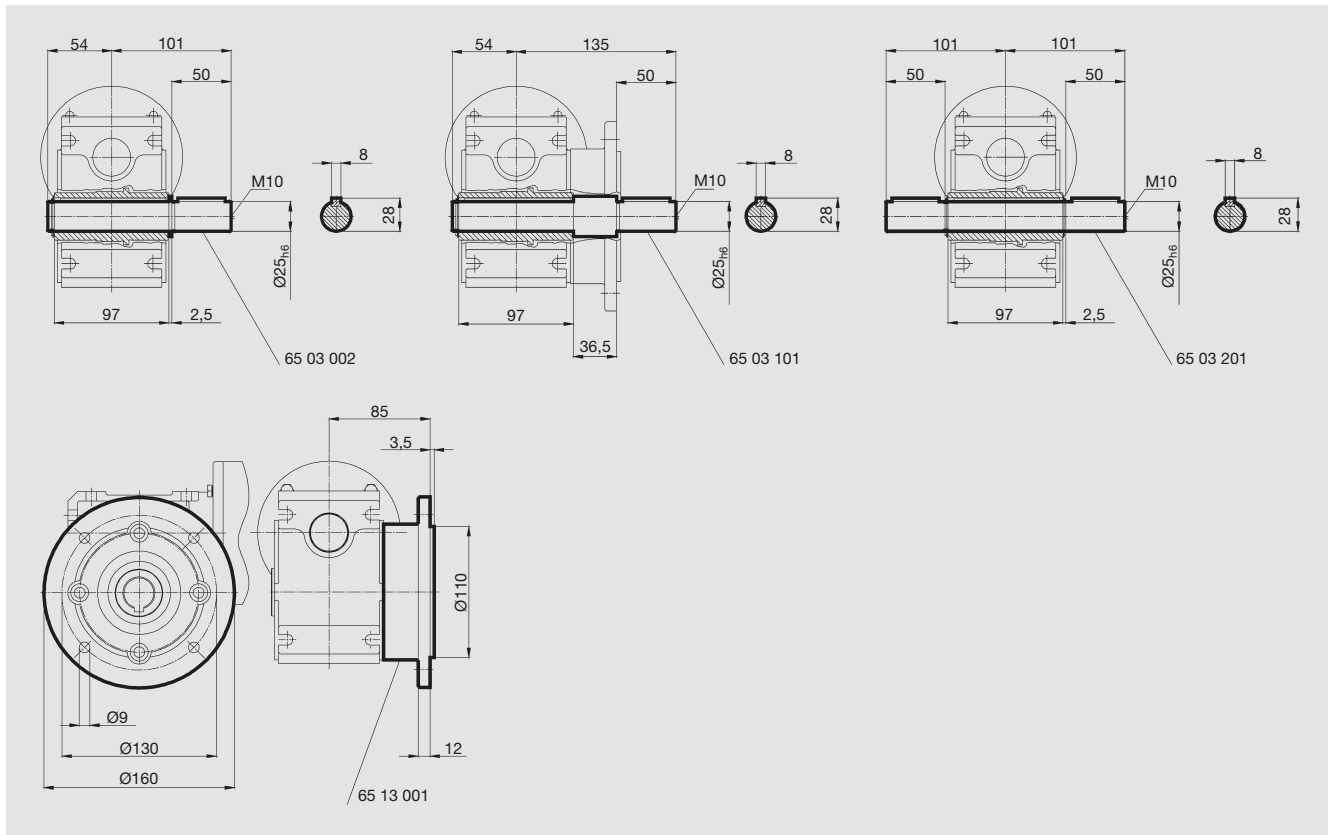

Bestell-Nr. Order code	Bild Fig.	Bezeichnung Description		kg
65 03 002	1	<b>Abtriebswelle einseitig kurz</b>	output shaft, one side, short	0,65
65 03 101	2	<b>Abtriebswelle einseitig lang</b>	output shaft, one side, long	0,90
65 03 201	3	<b>Abtriebswelle beidseitig</b>	output shaft, both sides	0,80
65 13 001	4	<b>Abtriebsflansch</b>	output flange	0,25



**ATLANTA**

**Grundgetriebe mit Antriebs-Hohlwelle**  
Basic gear with input hollow shaft

**Achsabstand / Centre distance**  $a_o = 63 \text{ mm}$  für B5 Motor / for B5 motor

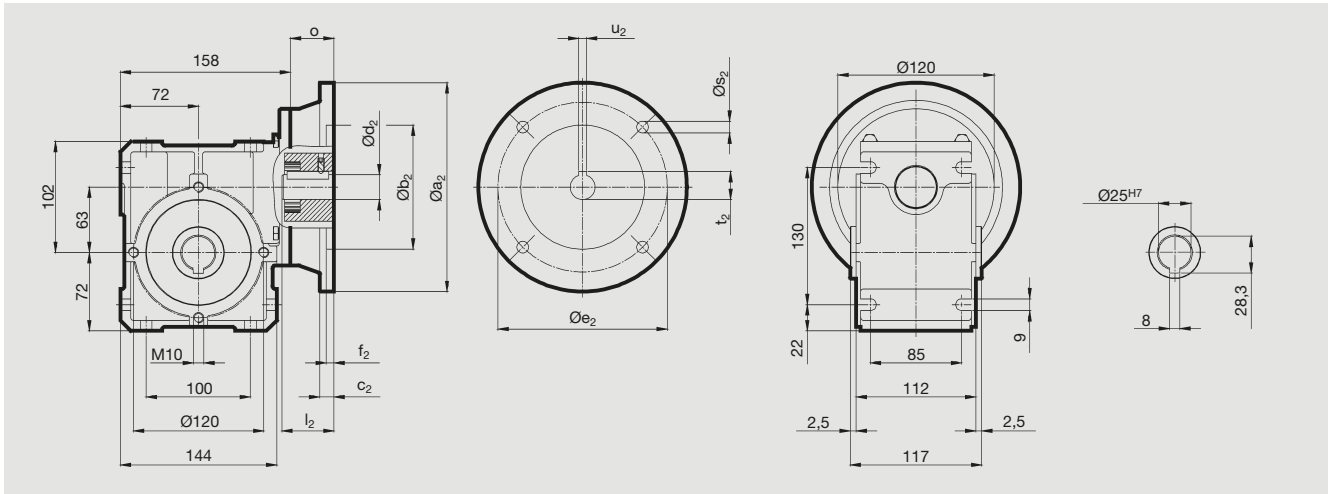

Bestell-Nr. Order code	Übersetzung Ratio	Antriebsflansch Driving flange	$a_2$	$b_2$	$c_2$	$d_2$	$e_2$	$f_2$	$l_2$	$o$	$s_2$	$t_2$	$u_2$	kg
76 34 305	5													
76 34 310	10													
76 34 320	20	IEC 56 B5 A120	120	80	8	9	100	3,5	20	32,5	7	11,4	3	7,8
76 34 330	30													
76 34 340	40													
76 34 350	50													
76 34 405	5													
76 34 410	10													
76 34 420	20	IEC 63 B5 A140	140	95	8	11	115	3,5	23	32,5	9	12,8	4	7,8
76 34 430	30													
76 34 440	40													
76 34 450	50													
76 34 505	5													
76 34 510	10													
76 34 520	20	IEC 71 B5 A160	160	110	8	14	130	4	30	32,5	9	16,3	5	7,8
76 34 530	30													
76 34 540	40													
76 34 550	50													
76 34 605	5													
76 34 610	10													
76 34 620	20	IEC 80 B5 A200	200	130	10	19	165	4	40	32,5	M10	21,8	6	7,8
76 34 630	30													
76 34 640	40													
76 34 650	50													
76 34 705	5													
76 34 710	10													
76 34 720	20	IEC 90 B5 A200	200	130	10	24	165	4	50	32,5	M10	27,3	8	7,8
76 34 730	30													
76 34 740	40													
76 34 750	50													

**Andere Übersetzungen auf Anfrage / Other ratios on request**



**Achsabstand / Centre distance**  $a_o = 63 \text{ mm}$  für B14 Motor / for B14 motor

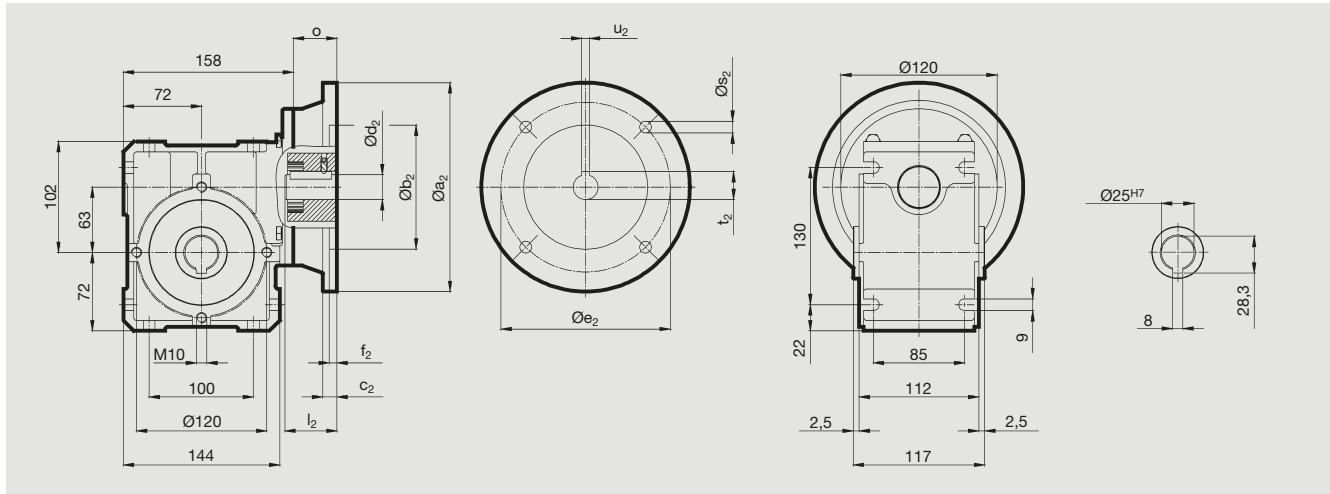

Bestell-Nr. Order code	Übersetzung Ratio	Antriebsflansch Driving flange	$a_2$	$b_2$	$c_2$	$d_2$	$e_2$	$f_2$	$l_2$	$o$	$s_2$	$t_2$	$u_2$	kg
76 44 205	5													
76 44 210	10													
76 44 220	20	IEC 56 B14 C105	105	70	8	9	85	3	20	32,5	7	11,4	3	7,8
76 44 230	30													
76 44 240	40													
76 44 250	50													
76 44 105	5													
76 44 110	10													
76 44 120	20	IEC 63 B14 C90	90	60	8	11	75	3	23	32,5	6	12,8	4	7,8
76 44 130	30													
76 44 140	40													
76 44 150	50													
76 44 305	5													
76 44 310	10													
76 44 320	20	IEC 63 B14 C120	120	80	8	11	100	3,5	23	32,5	7	12,8	4	7,8
76 44 330	30													
76 44 340	40													
76 44 350	50													
76 44 605	5													
76 44 610	10													
76 44 620	20	IEC 71 B14 C105	105	70	8	14	85	3	30	32,5	7	16,3	5	7,8
76 44 630	30													
76 44 640	40													
76 44 650	50													

Andere Übersetzungen auf Anfrage / Other ratios on request



**ATLANTA**

**Grundgetriebe mit Antriebs-Hohlwelle**  
Basic gear with input hollow shaft

**Achsabstand / Centre distance**  $a_o = 63 \text{ mm}$  für B14 Motor / for B14 motor

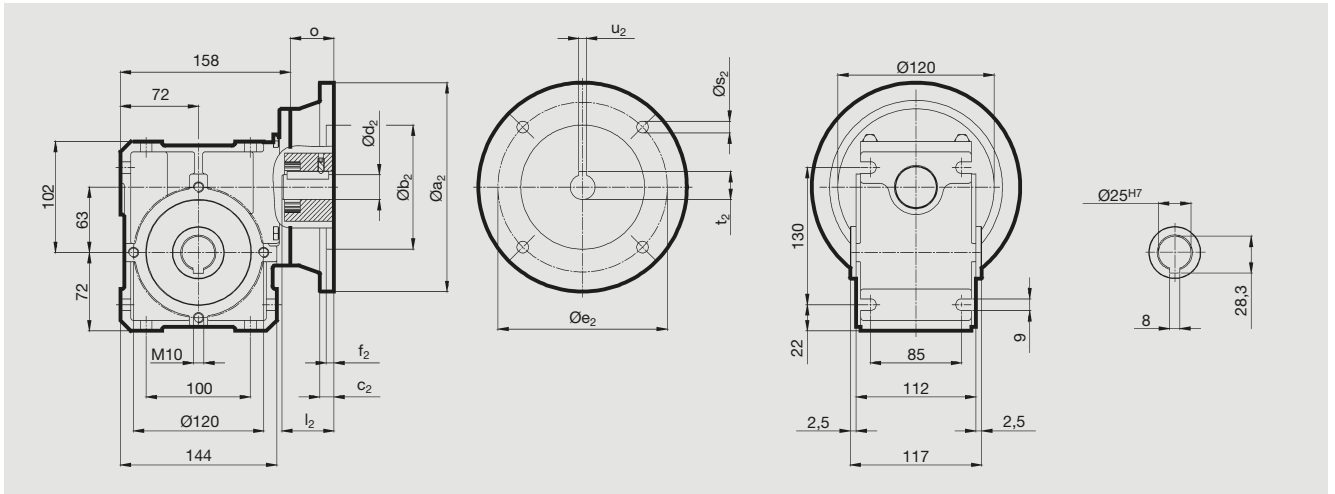

Bestell-Nr. Order code	Übersetzung Ratio	Antriebsflansch Driving flange	$a_2$	$b_2$	$c_2$	$d_2$	$e_2$	$f_2$	$l_2$	$o$	$s_2$	$t_2$	$u_2$	kg
76 44 405	5													
76 44 410	10													
76 44 420	20	IEC 71 B14 C140	140	95	8	14	115	3,5	30	32,5	9	16,3	5	7,8
76 44 430	30													
76 44 440	40													
76 44 450	50													
76 44 705	5													
76 44 710	10													
76 44 720	20	IEC 80 B14 C120	120	80	8	19	100	3,5	40	32,5	7	21,8	6	7,8
76 44 730	30													
76 44 740	40													
76 44 750	50													
76 44 505	5													
76 44 510	10													
76 44 520	20	IEC 80 B14 C160	160	110	8	19	130	4	40	32,5	9	21,8	6	7,8
76 44 530	30													
76 44 540	40													
76 44 550	50													
76 44 805	5													
76 44 810	10													
76 44 820	20	IEC 90 B14 C140	140	95	8	24	115	3,5	50	32,5	9	27,3	8	7,8
76 44 830	30													
76 44 840	40													
76 44 850	50													
76 44 905	5													
76 44 910	10													
76 44 920	20	IEC 90 B14 C160	160	110	8	24	130	4	50	32,5	9	27,3	8	7,8
76 44 930	30													
76 44 940	40													
76 44 950	50													

**Andere Übersetzungen auf Anfrage / Other ratios on request**





### Achsabstand / Centre distance $a_o = 63 \text{ mm}$

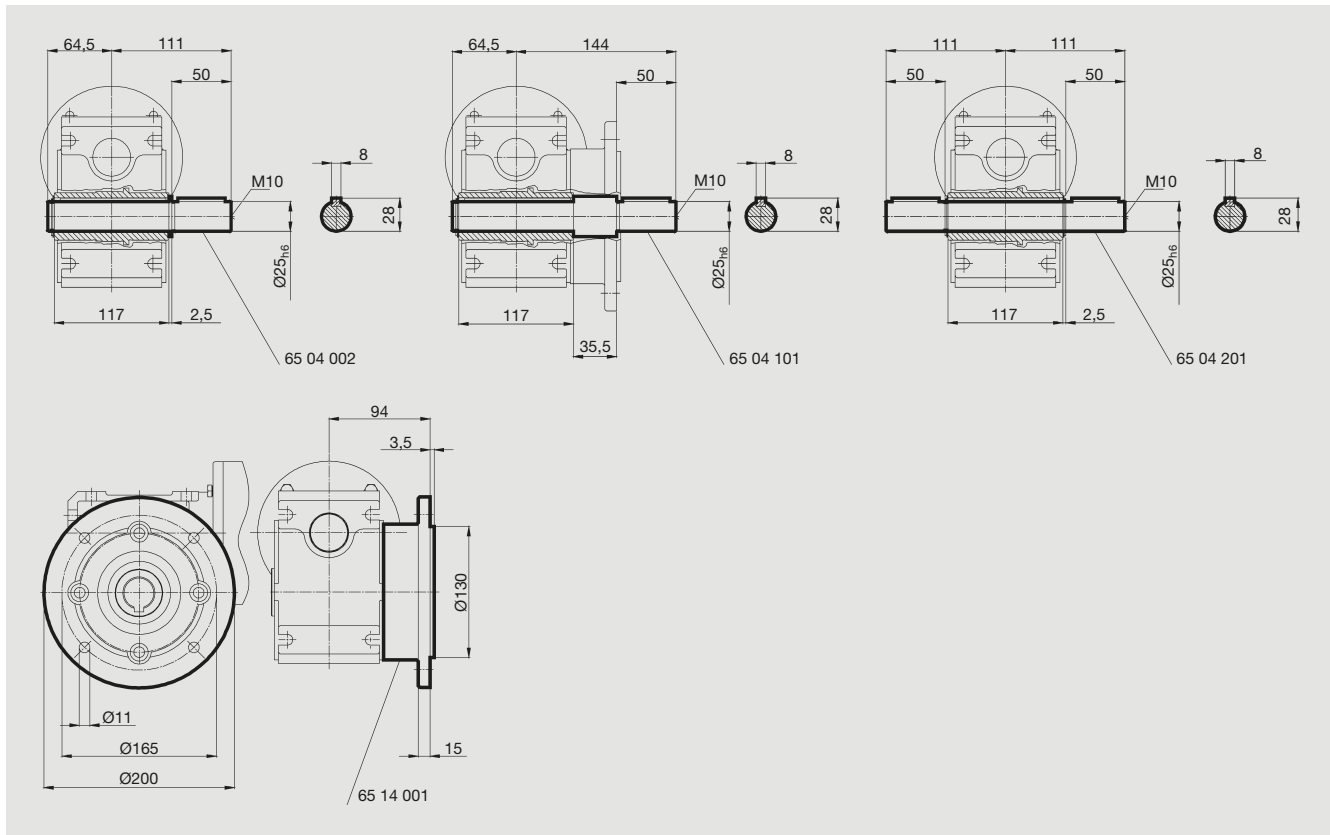

Bestell-Nr. Order code	Bild Fig.	Bezeichnung Description		kg
65 04 002	1	<b>Abtriebswelle einseitig kurz</b>	output shaft, one side, short	0,75
65 04 101	2	<b>Abtriebswelle einseitig lang</b>	output shaft, one side, long	1,00
65 04 201	3	<b>Abtriebswelle beidseitig</b>	output shaft, both sides	0,90
65 14 001	4	<b>Abtriebsflansch</b>	output flange	0,35



### Belastungs- und Auswahltabellen

(Tabellenwerte basieren auf der Temperatur- bzw. Flankengrenzleistung bei Verwendung synthetischer Öle)

#### Allgemeines

Für die Werte der Belastungstabelle wurde ein gleichmäßiger, stoßfreier Betrieb zugrunde gelegt. Da die Anwendungsfälle in der Praxis sehr verschieden sind, ist es erforderlich, die jeweiligen Verhältnisse durch entsprechende Faktoren  $S_H$ ,  $K_A$  und  $b_B$  zu berücksichtigen (siehe Seite A-18). Der Unterschied zwischen Ölsumpftemperatur und Umgebungstemperatur soll bei Dauerbetrieb 70 °C nicht überschreiten. Als Maximum für Ölsumpf gelten 110 °C.

Das zulässige Schneckenrad-Drehmoment beträgt:

$$T_{2zul.} = \frac{T_{2Tabelle}}{K_A \cdot S \cdot b_B} \quad [\text{Nm}]$$

Die erforderliche Antriebsleistung der Schneckenwelle beträgt:

$$P_{1erf.} = \frac{T_{2erf.} \cdot n_2}{9550 \cdot \eta} \quad [\text{kW}]$$

### Load and selection tables

(Values in the table are based on temperature limit respectively load limit of tooth profile when using synthetic oils)

#### General information

The values in the load tables are based on uniform, vibration free operation. Practical applications differ substantially from one another, therefore it is necessary to consider the respective conditions by allowing for the appropriate factors  $S_H$ ,  $K_A$  and  $b_B$  (see page A-18). The difference between oil sump temperature and ambient temperature should not exceed 70 °C during continuous operation. Maximum oil sump temperature is 110 °C.

The maximum admissible wormgear torque is:

$$T_{2perm.} = \frac{T_{2Tabelle}}{K_A \cdot S \cdot b_B} \quad [\text{Nm}]$$

The input power required of the wormshaft is:

$$P_{1req.} = \frac{T_{2req.} \cdot n_2}{9550 \cdot \eta} \quad [\text{kW}]$$

Antriebs-Nennleistung	Input rated capacity	$P_1$	=	[kW]
Abtriebsmoment	Output torque	$T_2$	=	[Nm]
Max. Drehmoment (Biegegrenze)	Max. torque (bending limit)	$T_{2max}$	=	[Nm]
Wirkungsgrad $\eta$	Efficiency $\eta$		=	[ ]
Verlust-Leistung	Power loss		=	[kW]

Bestell-Nr. Order code	$a_o$ (mm)	i	$T_{2max}$	Antriebsdrehzahl ( $n_1$ ) min <sup>-1</sup> / Driving speed ( $n_1$ ) rpm								$\eta$ bei / at 1400
				500		900		1400		2800		
				$P_1$	$T_2$	$P_1$	$T_2$	$P_1$	$T_2$	$P_1$	$T_2$	
<b>76_1_05</b>	<b>31</b>	5	75	0,39	31	0,60	27	0,79	23	1,20	18	0,86
<b>76_1_10</b>		10	75	0,24	34	0,36	30	0,47	26	0,71	20	0,80
<b>76_1_20</b>		20	75	0,15	37	0,23	32	0,30	27	0,44	21	0,67
<b>76_1_30</b>		30	75	0,15	40	0,21	35	0,27	30	0,39	23	0,55
<b>76_1_40</b>		40	75	0,11	37	0,16	32	0,20	28	0,29	22	0,50
<b>76_1_50</b>		50	75	0,09	35	0,13	30	0,17	26	0,24	20	0,45
<b>76_2_05</b>	<b>40</b>	5	125	0,63	51	0,96	45	1,27	38	1,94	30	0,88
<b>76_2_10</b>		10	125	0,38	57	0,58	50	0,76	42	1,14	33	0,82
<b>76_2_20</b>		20	125	0,25	61	0,37	53	0,47	45	0,69	35	0,71
<b>76_2_30</b>		30	125	0,23	68	0,32	58	0,41	50	0,59	39	0,60
<b>76_2_40</b>		40	125	0,17	62	0,24	54	0,31	46	0,45	36	0,54
<b>76_2_50</b>		50	125	0,14	58	0,20	50	0,25	43	0,36	33	0,50
<b>76_3_05</b>	<b>50</b>	5	225	1,07	89	1,63	77	2,15	66	3,32	51	0,90
<b>76_3_10</b>		10	225	0,66	102	1,00	88	1,30	75	1,98	59	0,85
<b>76_3_20</b>		20	225	0,42	109	0,61	95	0,79	81	1,18	63	0,75
<b>76_3_30</b>		30	225	0,38	122	0,54	105	0,68	90	0,99	70	0,65
<b>76_3_40</b>		40	225	0,27	112	0,40	97	0,50	83	0,74	65	0,60
<b>76_3_50</b>		50	225	0,23	104	0,33	90	0,40	77	0,58	60	0,56
<b>76_4_05</b>	<b>63</b>	5	400	1,87	159	2,85	138	3,75	118	5,8	92	0,92
<b>76_4_10</b>		10	400	1,14	181	1,72	157	2,26	134	3,5	105	0,87
<b>76_4_20</b>		20	400	0,71	195	1,05	169	1,3	144	2,0	113	0,79
<b>76_4_30</b>		30	400	0,64	216	0,90	187	1,1	160	1,7	125	0,69
<b>76_4_40</b>		40	400	0,45	198	0,65	172	0,84	147	1,2	115	0,64
<b>76_4_50</b>		50	400	0,38	185	0,53	160	0,66	137	0,97	107	0,61

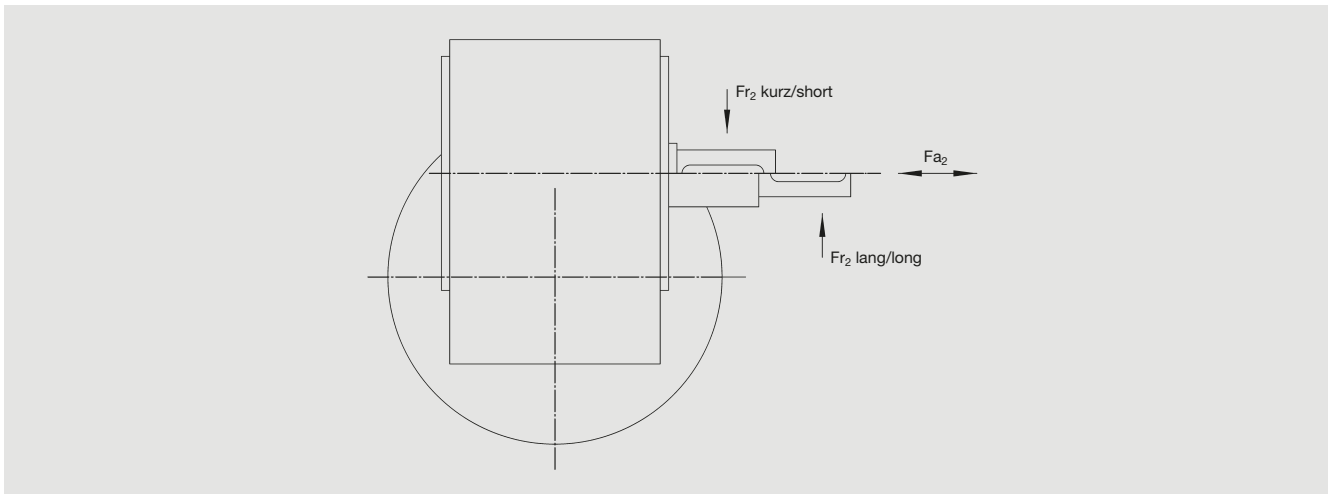

Zulässige Kraft Admissible force	i	Achsabstand / Centre distance							
		31		40		50		63	
		Kurz short	Lang long	Kurz short	Lang long	Kurz short	Lang long	Kurz short	Lang long
<b>Radialkraft <math>Fr_2</math> (N)</b> Transverse load	5	1140	1040	2720	1840	4800	3730	6300	3450
	10	1380	1030	3200	1810	4800	3700	6300	3420
	20	1650	990	3200	1790	4800	3710	6300	3320
	30	1800	1010	3200	1800	4800	3680	6300	3200
	40	1800	990	3200	1790	4800	3690	6300	3260
	50	1800	1010	3200	1810	4800	3670	6300	3320
<b>Axialkraft <math>Fa_2</math> (N)</b> Axial load		1800		3200		4800		6300	

Für die Berechnung der Radialkraft liegt die Krafteinleitung in der Mitte der Wellenzapfen unserer Einsteckwellen zugrunde.

The calculation of the radial force is based upon power input in the middle of the shaft end of our output shafts.

### Kurzbeschreibung

Die Schneckengetriebe „leichte Ausführung“ ermöglichen mit ihren vielen Befestigungs- und Gewindebohrungen einen problemlosen An- und Einbau in jeder beliebigen Lage.

Die Getriebe sind mit einem synthetischen Langzeitschmierstoff hermetisch lebensdauergeschmiert, Öl-Nachfüll- und Ablassbohrungen können daher entfallen.

Die Selbsthemmung und Selbstbremsung bei Schneckengetrieben ist abhängig von der Übersetzung.

Bei i 5 und 10 besteht keine Selbsthemmung und Selbstbremsung, ab i 20 bis i 40 ist keine zuverlässige Selbsthemmung/keine Selbstbremsung vorhanden. Von i 50 bis i 80 ist statische Selbsthemmung (in Ruhe und bei Erschütterungsfreiheit), aber keine zuverlässige Selbstbremsung (siehe auch Seite A-23).

Der Anbau von IEC- Normmotoren in Bauform B5 bzw. B14 am Getriebe wird mit entsprechend passenden Antriebsflanschen und Kupplungen angeboten. Die Drehstrom-Asynchronmotoren sind auch in folgenden Ausführungen lieferbar: polumschaltbar, mit Bremse, mit 2. Wellenende, mit Kaltleiterfühler, mit Fremdlüfter oder Ausführung nach ATEX.

Digitale Frequenzumrichter zur elektronischen Drehzahlverstellung komplettieren das Angebot.

Für weitere Informationen und Anfragen stehen Ihnen unsere Mitarbeiter jederzeit gerne zur Verfügung.

### Short description

The „light-version“ worm-gear units with their numerous fixing holes and threaded bores make it possible to attach and/or install them without problems in any position desired.

The gearboxes are hermetically sealed and lifetime-lubricated with long-time lubricant so that no refilling or draining holes are necessary.

The self-locking and self-braking capacities of the worm-gear units depend upon the gear ratio.

The i 5 and i10 are neither self-locking nor self-braking; from i 20 to i 40 there is no reliable self-locking/no self-braking effect. From i 50 to i 80 static self-locking exists (at rest and without vibrations), but no reliable self-braking (see also page A-23).

Type B5 or B14 standard IEC motors can be attached to the gearbox by means of suitable input flanges and clutches supplied by Atlanta. The three-phase AC asynchronous motors are also available as follows: pole-changing version, with brake, with second shaft end, with thermistor probe, with external ventilator or as version according to ATEX.

Digital frequency converters for the electronic speed control complete the available program.

Our staff will be glad to answer your questions and give you further information.

